

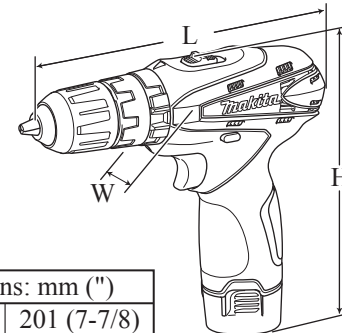

TECHNICAL INFORMATION

Models No. ▶ HP330D

Description ▶ 10.8V Cordless Hammer Driver Drill



CONCEPT AND MAIN APPLICATIONS

Model HP330D is Makita first 10.8V cordless hammer driver drill.
It is ideal specially for drilling holes into mortar by using hammer drill mode.
LED job light with pre-grow function is adapted. (DF330D: after-grow)
The others except above are the same as DF330D.

Dimensions: mm (")	
Length (L)	201 (7-7/8)
Width (W)	53 (2-1/16)
Height (H)	183 (7-1/4)

This product is available in the following variations.

Model No.	Housing color	Battery		Charger		Rechargeable flash light	Plastic carrying case	Offered to
		type	q'ty	Model	Color			
HP330DZ	Makita-blue	BL1013 (Li-ion 1.3Ah)	---	---	---	No	No	All countries except below countries
HP330DWE			2	DC10WA	Makita-blue		ML100	
HP330DWLE			---	---	---	---	No	
---	white	BL1014 (Li-ion 1.3Ah)	2	DC10WB	Black	Yes		
---			---	---	---	No		
---			2	DC10WB	Black	Yes		

The models also includes the accessories listed below in "Standard equipment".

▶ Specification

Battery	Type of cell	Li-ion
	Voltage: V	10.8*2, (10.8/12V max*3)
	Capacity: Ah	1.3
	Energy capacity: Wh	14
	Charging time (approx.): min.	50 with DC10WA*2, (DW10WB*3)
Max output: W		140
No load speed: min ⁻¹ =rpm	High	0 - 1,500
	Low	0 - 400
Impacts per minute: min ⁻¹ =ipm	High	0 - 22,500
	Low	0 - 6,000
Capacity of drill chuck: mm (")		0.8 (1/32) - 10 (3/8)
Capacities: mm (")	Steel	10 (3/8)
	Wood	21 (13/16)
	Masonry	8 (5/16)
Torque adjustment		18 stages + drill mode
Clutch torque setting: N.m (in.lbs)		0.5 - 3.5 (4 - 30)
Max fastening torque: N.m (in.lbs)	Soft joint	12 (110)
	Hard joint	24 (210)
Max lock torque: N.m (in.lbs)		22 (200)
Electric brake		Yes
Variable speed control by trigger		Yes
Mechanical 2-speed		Yes
Reverse switch		Yes
LED job light		Yes (single LED)
Weight according to EPTA-Procedure 01/2003*4: kg (lbs)		1.1 (2.3)

*2 For all countries except North and Central American countries (Mexico and Guam are included.)

*3 For North and Central American countries except Mexico and Guam *4 with battery

▶ Standard equipment

+ bit 2-65	1
Holster	1
Aluminum case assembly	1
(for some country only)	

Note: The standard equipment for the tool shown above may vary by country.

▶ Optional accessories

Driver bits, Socket bits, Drill bits for wood,
Drill bits for steel, Drill bits for masonry,
Charger DC10WA*2, Charger DC10WB*3,
Battery BL1013*2, Battery BL1014*3

► **Repair**

CAUTION: Repair the machine in accordance with “Instruction manual” or “Safety instructions”.

[1] NECESSARY REPAIRING TOOLS

Code No.	Description	Use for
1R359	Drill chuck removing tool	(Use this tool if Drill chuck cannot be removed by the method of described in “[3]-1 Drill chuck disassembling”.)
—	Hex wrench 8	removing/ mounting Drill chuck

[2] LUBRICATION

It is not required to lubricate the gear section because the portion is replaced as a factory-assembled gear unit.

[3] DISASSEMBLY/ASSEMBLY

[3] -1. Drill chuck

DISASSEMBLING

Note: It is required to remove Drill chuck when replacing Gear assembly, but you need not when replacing the parts that are independent of Gear assembly.

(1) Set the machine and repairing tools. (Figs. 1, 2, 3)

Fig. 1

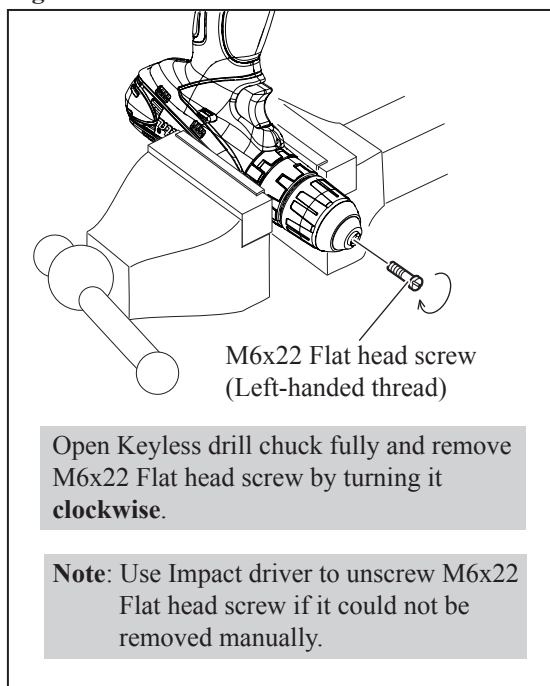

Fig. 2

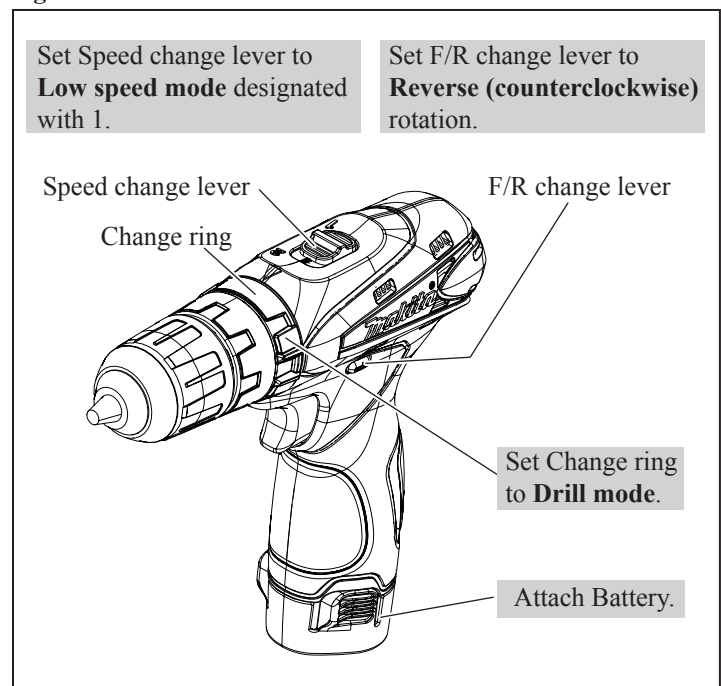
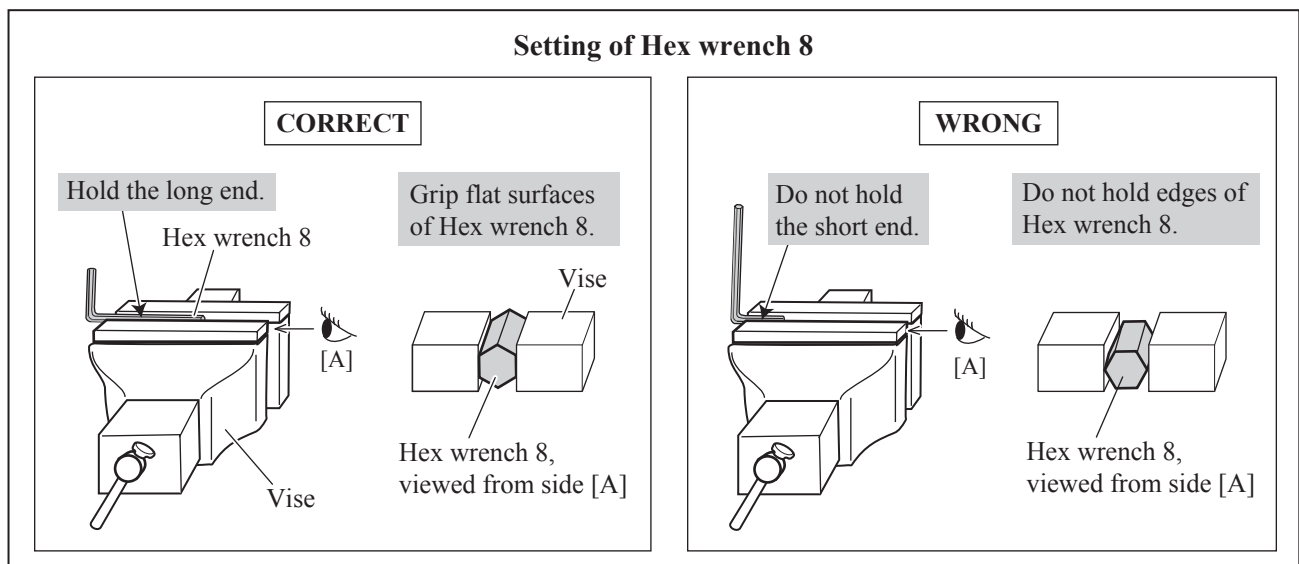

Fig. 3



► **Repair**

[3] DISASSEMBLY/ASSEMBLY

[3] -1. Drill Chuck (cont.)

DISASSEMBLING

(2) Remove Drill chuck. (Fig. 4)

Fig. 4

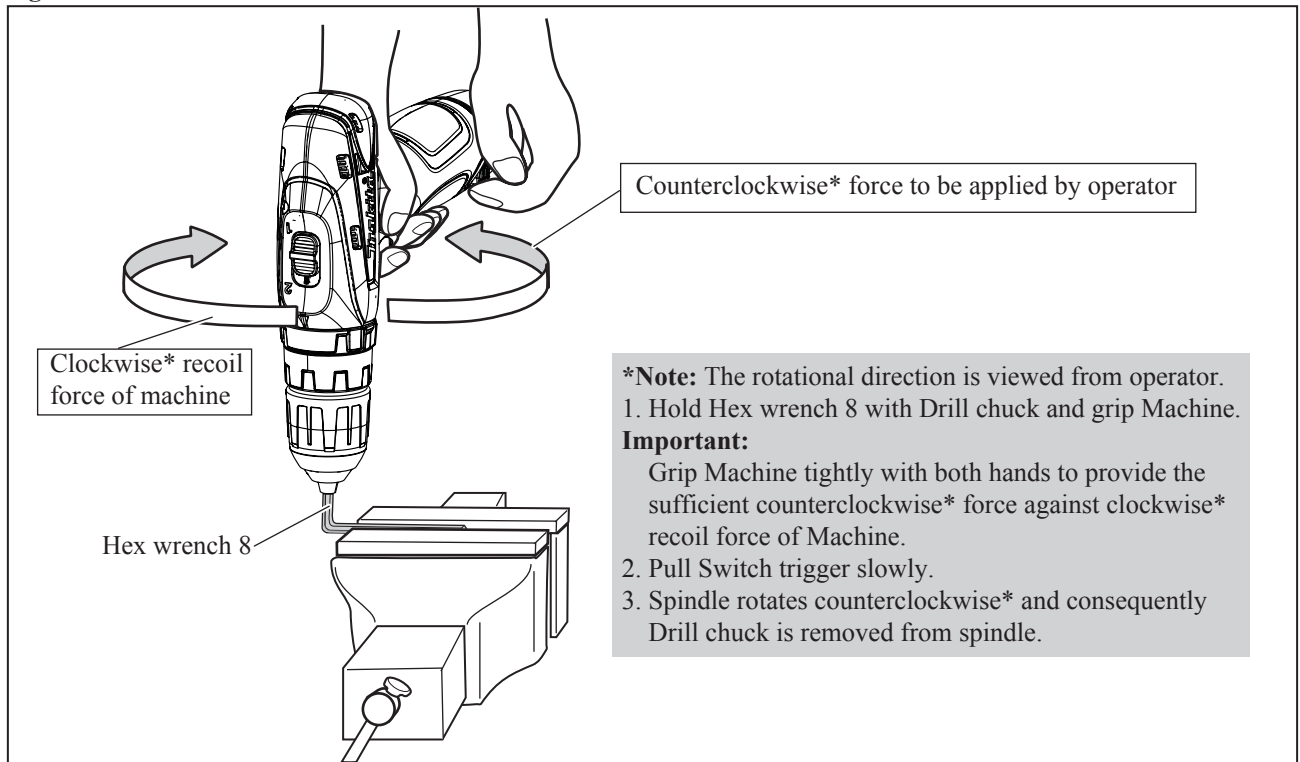

ASSEMBLING

(1) Set the machine. (Fig. 5 and 6)

(2) Set Hex wrench 8 to vise and described in Fig. 3.

Fig. 5

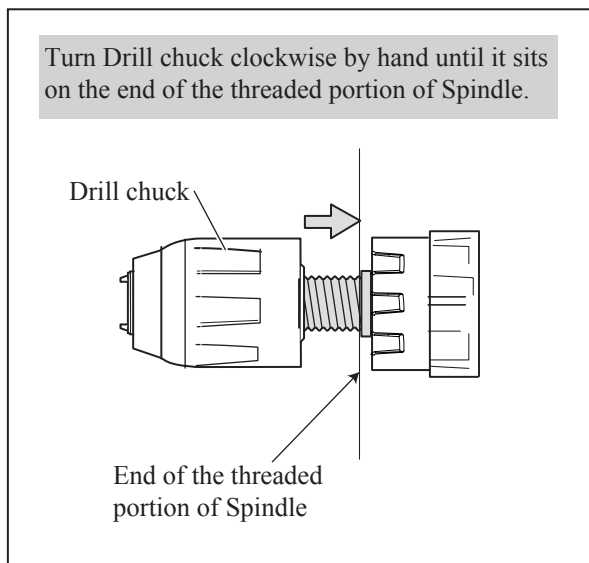
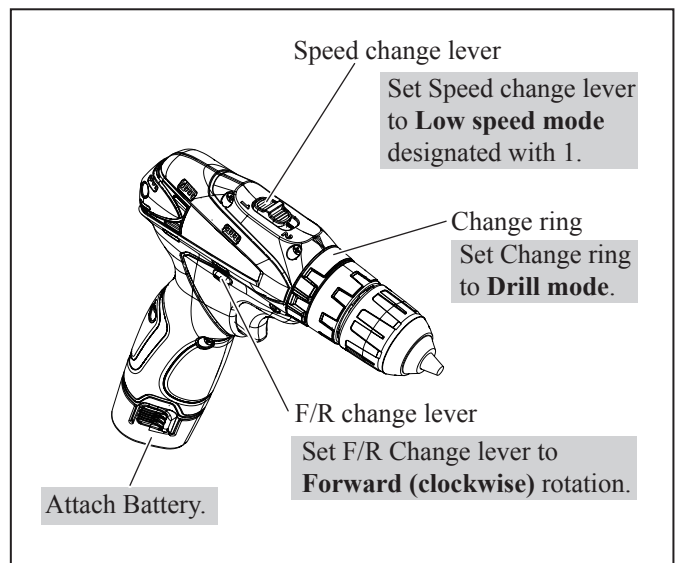

Fig. 6



► **Repair**

[3] DISASSEMBLY/ASSEMBLY

[3] -1. Drill chuck (cont.)

ASSEMBLING

(3) Set Drill chuck in place. (Fig. 7)

Fig. 7

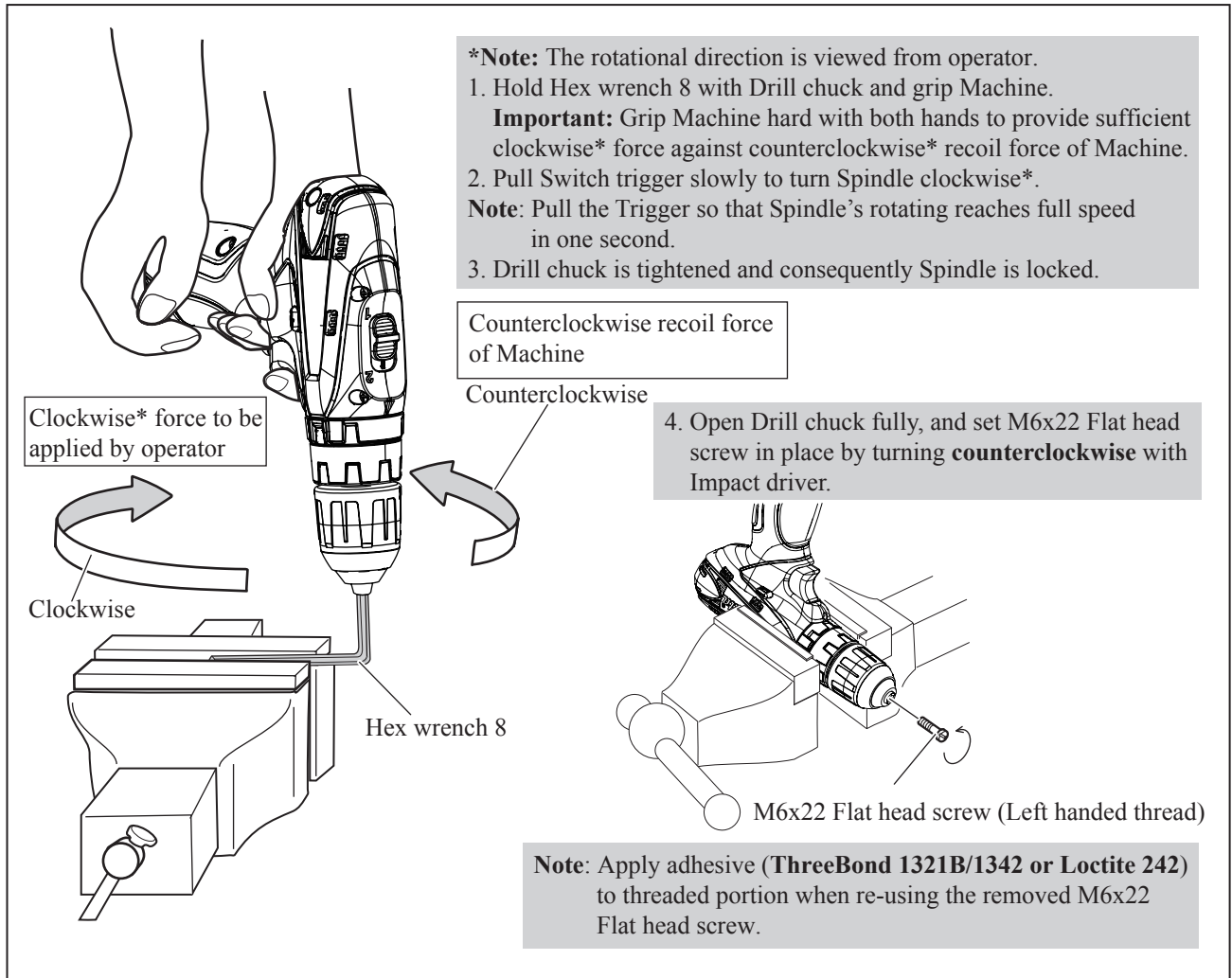

► **Repair**

[3] DISASSEMBLY/ASSEMBLY

[3] -2. Gear assembly, Motor section

DISASSEMBLING

(1) Remove Drill chuck. (Figs. 1, 2, 3)

Note: It is not required to remove Drill chuck when replacing only DC motor.

(2) Remove Housing R from Housing L. (Fig. 8)

Fig. 8

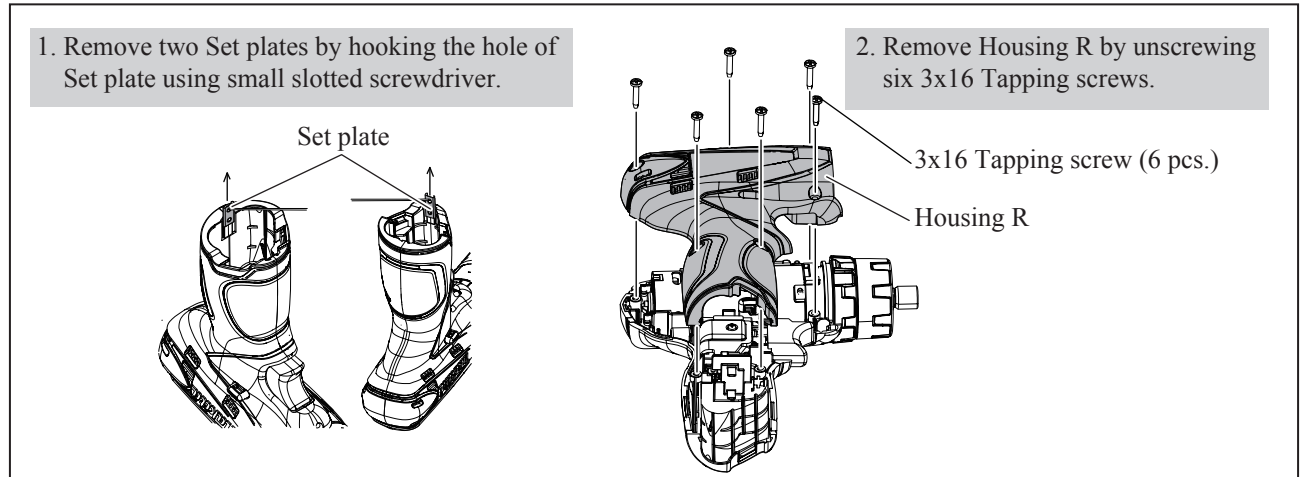

(3) Separate DC motor from Gear assembly. (Fig. 9)

Fig. 9

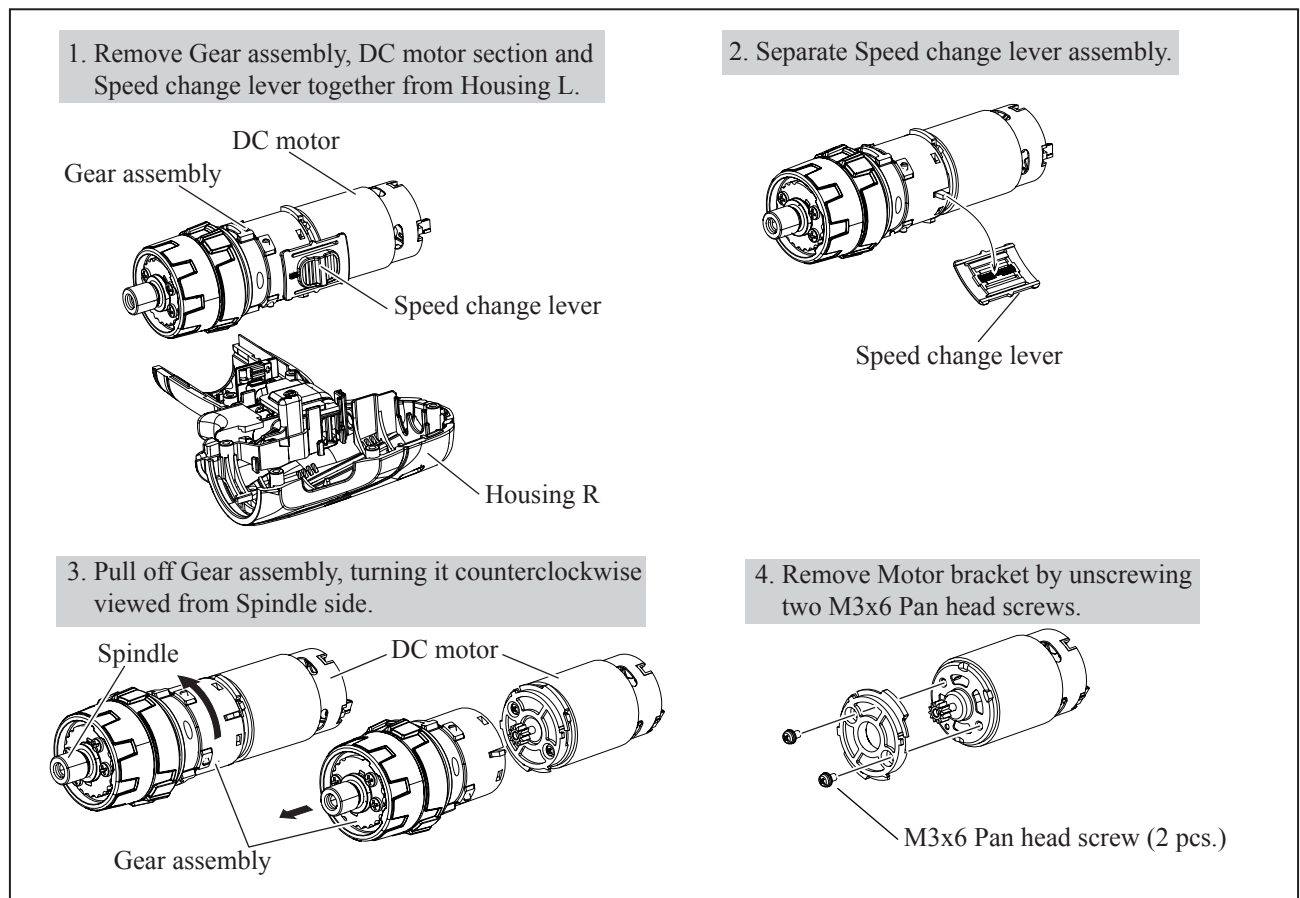

► **Repair**

[3] DISASSEMBLY/ASSEMBLY

[3] -2. Gear assembly, Motor section (cont.)

ASSEMBLING

(1) Assemble Gear assembly to DC motor. (Fig. 10)

Fig. 10

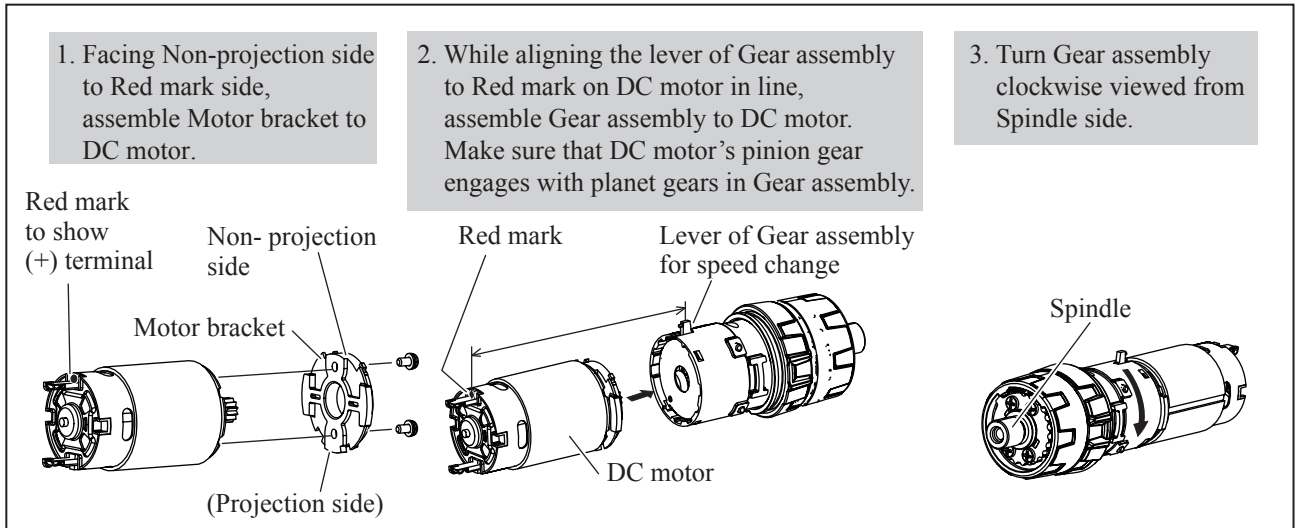

(2) Assemble Speed change lever to Lever of Gear assembly. (Fig. 11)

Fig. 11

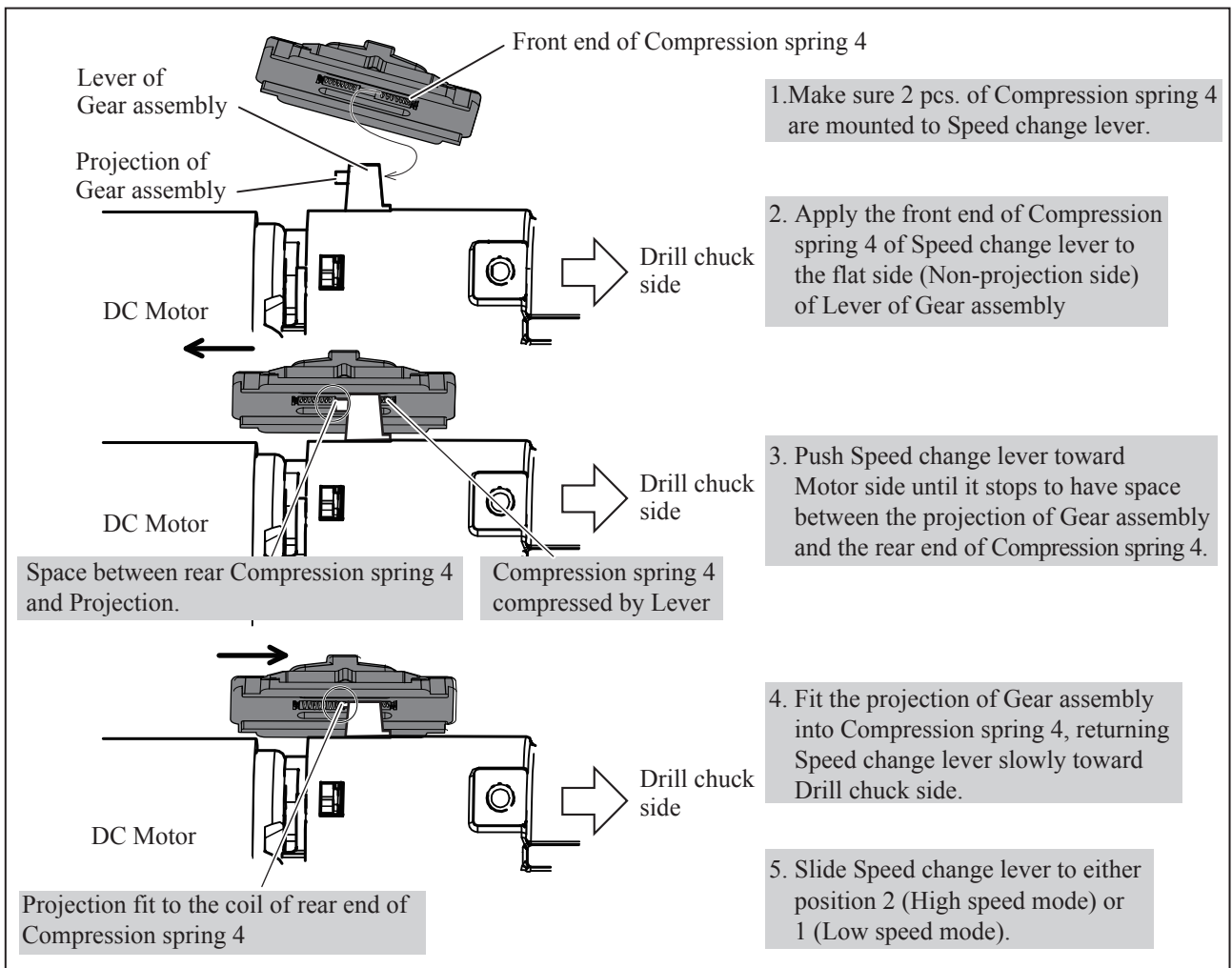

► **Repair**

[3] DISASSEMBLY/ASSEMBLY

[3] -2. Gear assembly, Motor section (cont.)

ASSEMBLING

(3) Before setting Gear assembly and DC motor, take the following step in **Fig. 12**.

Fig. 12

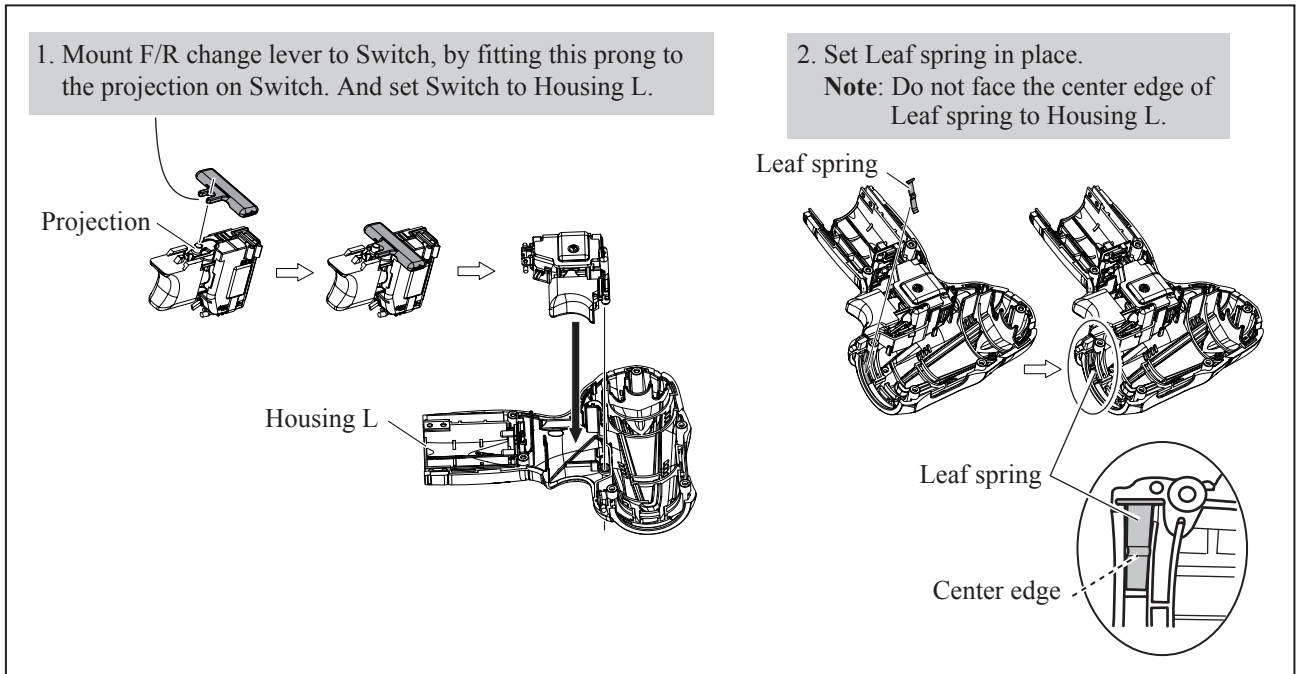

(4) Setting Gear assembly and DC motor to Housing L, fasten Housing R with six 3x16 Tapping screws. (**Fig. 13**)

Fig. 13

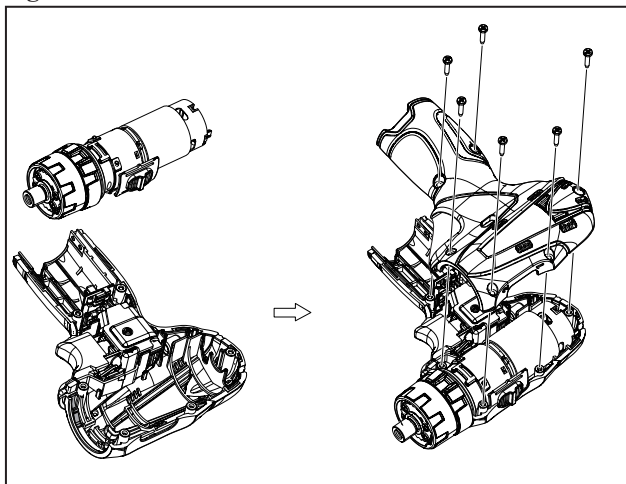

(5) Set Drill chuck in place. (**Figs. 5, 6, 7**)

► **Circuit diagram**

Fig. D-1

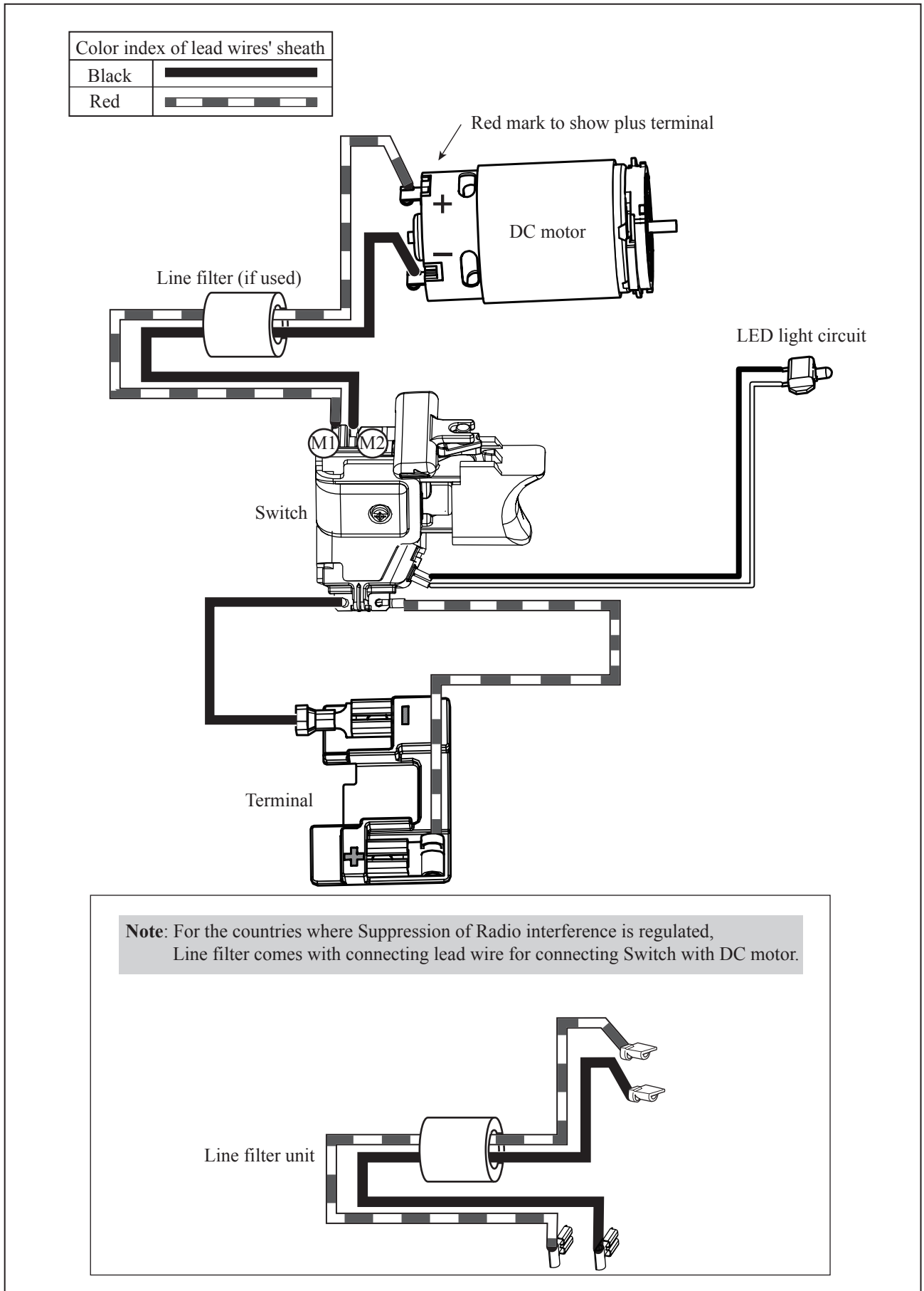

► **Wiring diagram**

Flag connectors have to be connected to the electrical parts as drawn in **Fig. D-2**.

Fig. D-2

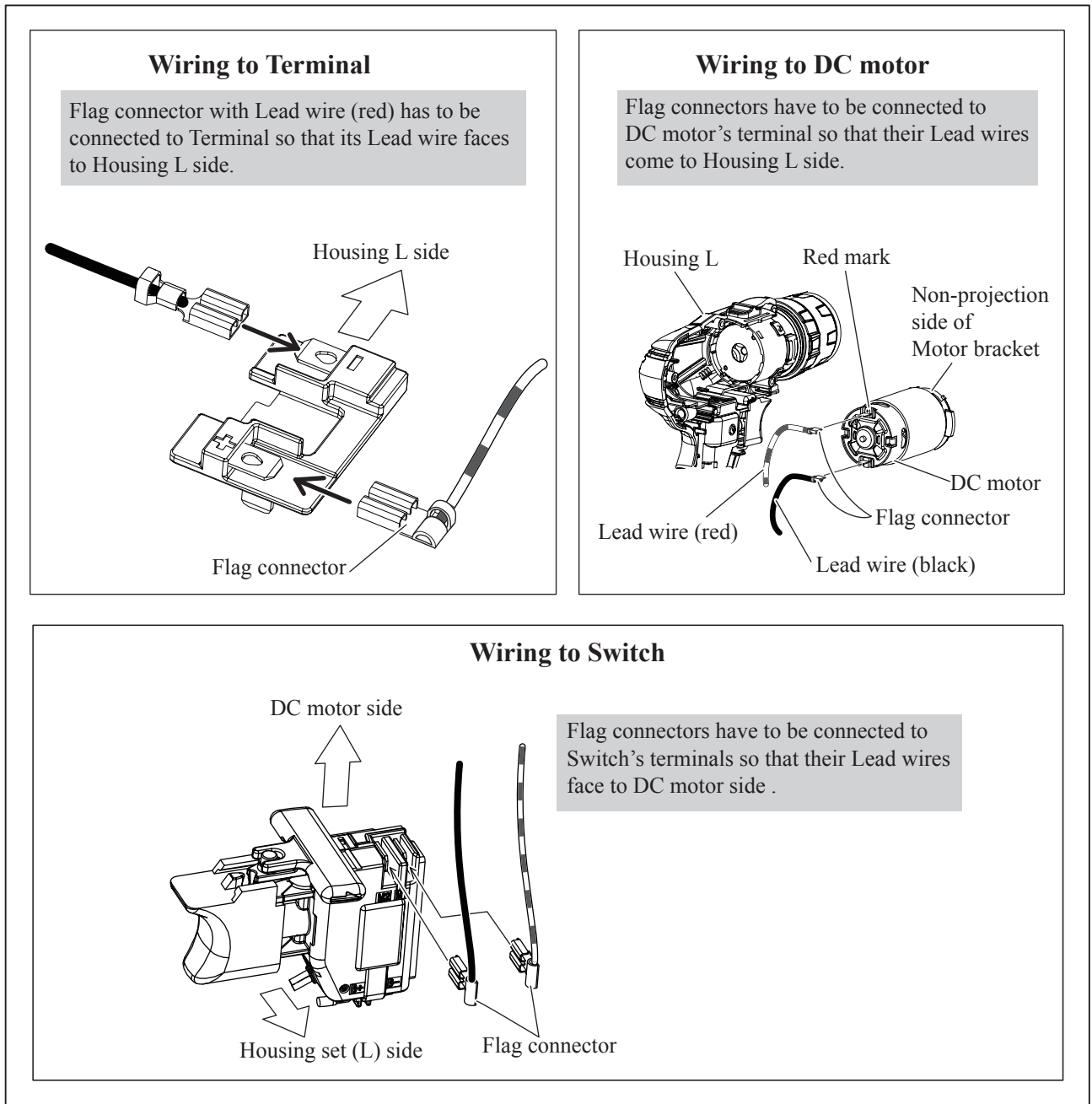

▶ Wiring diagram

Route LED lead wires in Housing set (L) as drawn in **Fig. D-3**.

Fig. D-3

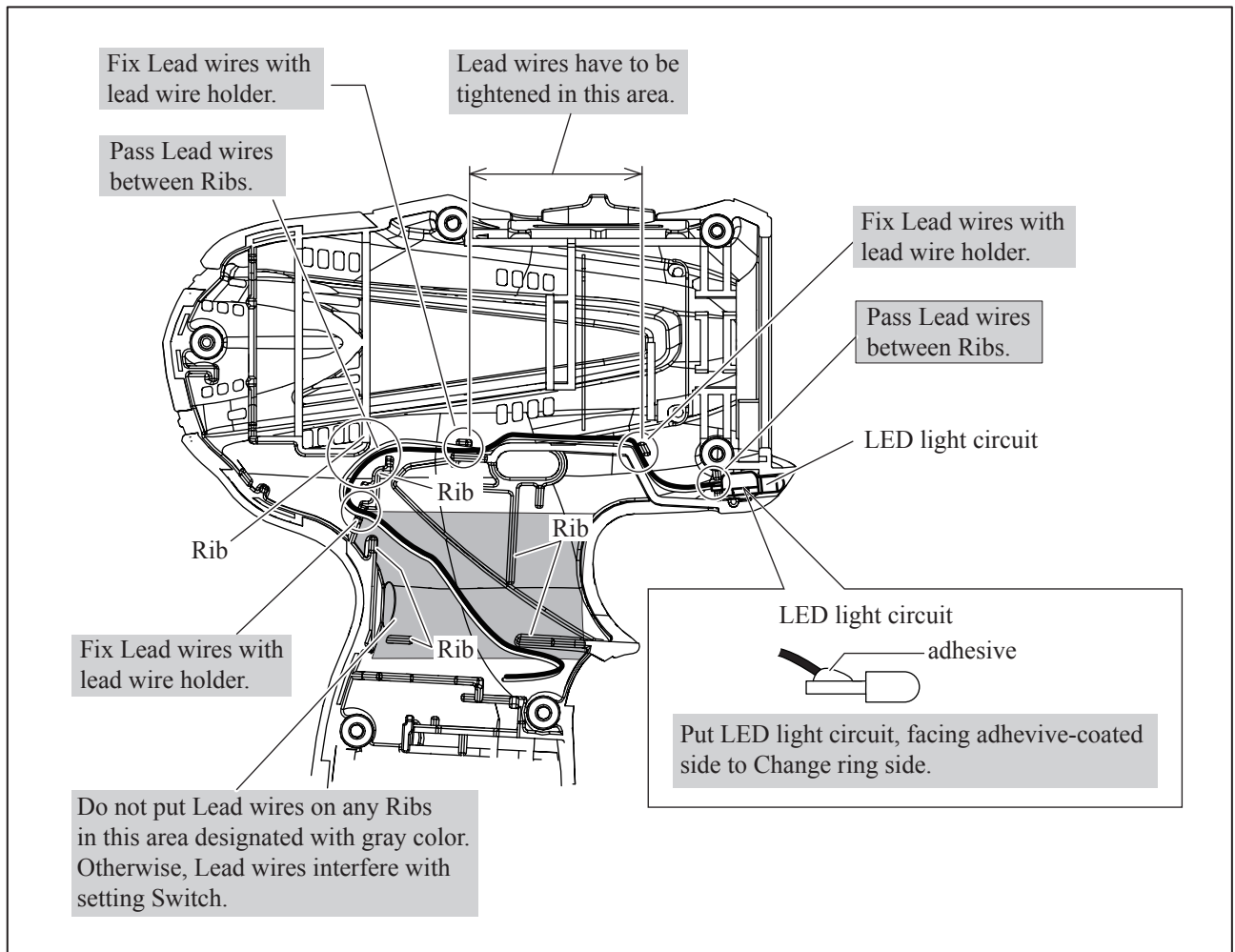

► **Wiring diagram**

Route lead wires except for LED in Housing L. (**Fig. D-4**)

Fig. D-4

