

40A TRIACS

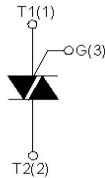
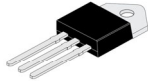

TOP-3

**BTA41-600/
800/1200/1600**

**TOP-3
(Insulated Tab)
Leaded Plastic
Package
RoHS compliant**

FEATURES:

1. High ability to withstand the shock loading of large current
2. Provide high dv/dt rate with strong resistance to electromagnetic interference
3. High commutation performances, 3 quadrants products especially recommended for use on inductive load.
4. From all three terminals to external heatsink, BTA 41 provides a rated insulation voltage of 2500 VRMS, complying with UL standards

APPLICATIONS:

1. On/off function in static relays, heating regulation, induction motor starting circuits
2. Phase control operations in light dimmers, motor speed controllers, and similar applications

ABSOLUTE MAXIMUM RATINGS (T_a = 25 °C)

PARAMETER	SYMBOL	VALUE	UNIT
Storage junction temperature range	T _{stg}	-40 to 150	°C
Operating junction temperature range	T _j	-40 to 125	°C
Repetitive peak off-state voltage (T _j =25°C)	V _{DRM}	600/800/1200/1600	V
Repetitive peak reverse voltage (T _j =25°C)	V _{RRM}	600/800/1200/1600	V
Non repetitive surge peak Off-state voltage	V _{DSM}	V _{DRM} +100	V
Non repetitive peak reverse voltage	V _{RSM}	V _{RRM} +100	V
RMS on-state current (T _C =80°C)	I _{T(RMS)}	40	A
Non repetitive surge peak on-state current (full cycle, F=50Hz)	I _{TSM}	400	A
I ² t value for fusing (t _p =10ms)	I ² t	880	A ² s
Critical rate of rise of on-state current (I _G =2×I _{GT})	di/dt	50	A/μs
Peak gate current	I _{GM}	4	A
Average gate power dissipation	P _{G(AV)}	1	W
Peak gate power	P _{GM}	10	W

BTA41

Rev3_29032023EBJ



Continental Device India Pvt. Limited

An IATF 16949, ISO9001 and ISO 14001/ISO 45001 Certified Company



ELECTRICAL CHARACTERISTICS at $T_a = 25^\circ\text{C}$ (Unless otherwise specified)

3 Quadrants							
PARAMETER	SYMBOL	TEST CONDITIONS	QUADRANT	VALUE			UNITS
					BW	CW	
Gate Trigger Current	I_{GT}	$V_D = 12V$ $R_L = 33\Omega$	I - II - III	MAX	50	35	mA
Gate Trigger Voltage	V_{GT}		I - II - III	MAX	1.3		V
Off-State Gate Voltage	V_{GD}	$V_D = V_{DRM}$, $T_j = 125^\circ\text{C}$, $R_L = 3.3K\Omega$	I - II - III	MIN	0.2		V
Latching Current	I_L	$I_G = 1.2I_{GT}$	I - III	MAX	80	70	mA
			II		100	80	
Holding Current	I_H	$I_T = 100\text{mA}$		MAX	60	50	mA
Critical Rate of Rise of Off-State Voltage	dV/dt	$V_D = 2/3V_{DRM}$, Gate Open $T_j = 125^\circ\text{C}$		MIN	1500	1000	V/ μs

4 Quadrants

							B		
Gate Trigger Current	I_{GT}	$V_D = 12V$ $R_L = 33\Omega$	I - II - III	MAX	50		mA		
			IV		70				
Gate Trigger Voltage	V_{GT}		ALL	MAX	1.3		V		
Off-State Gate Voltage	V_{GD}	$V_D = V_{DRM}$, $T_j = 125^\circ\text{C}$, $R_L = 3.3K\Omega$	ALL	MIN	0.2		V		
Latching Current	I_L	$I_G = 1.2I_{GT}$	I - III - IV	MAX	90		mA		
			II		100				
Holding Current	I_H	$I_T = 100\text{mA}$		MAX	80		mA		
Critical Rate of Rise of Off-State Voltage	dV/dt	$V_D = 2/3V_{DRM}$ Gate Open	$T_j = 125^\circ\text{C}$	MIN	1000		V/ μs		
Maximum Threshold voltage	V_{TM}	$I_{TM} = 60A$ $t_p = 380\mu\text{s}$	$T_j = 25^\circ\text{C}$	MAX	1.5		V		
Pulsed reverse drain current	I_{DRM}	$V_D = V_{DRM}$ $V_R = V_{RRM}$	$T_j = 25^\circ\text{C}$		10		μA		
Maximum reverse leakage current	I_{RRM}		$T_j = 125^\circ\text{C}$		5		mA		

STATIC CHARACTERISTICS

On-State Voltage	V_{TM}	$I_{TM} = 60A$, $t_p = 380\mu\text{s}$,	$T_j = 25^\circ\text{C}$	MAX	1.55	V
Off-State Leakage Current	I_{DRM}	$V_D = V_{DRM}$ $V_R = V_{RRM}$	$T_j = 25^\circ\text{C}$	MAX	10	μA
	I_{RRM}		$T_j = 125^\circ\text{C}$	MAX	5	mA

THERMAL RESISTANCES

Junction to case (AC)	$R_{th(j-c)}$				1.1	$^\circ\text{C/W}$
-----------------------	---------------	--	--	--	-----	--------------------

BTA41

Rev3_29032023EJB

Recommended Reflow Solder Profiles

The recommended reflow solder profiles for Pb and Pb-free devices are shown below.

Figure 1 shows the recommended solder profile for devices that have Pb-free terminal plating, and where a Figure 2 shows the recommended solder profile for devices with Pb-free terminal plating used with leaded

Figure 1

Figure 2

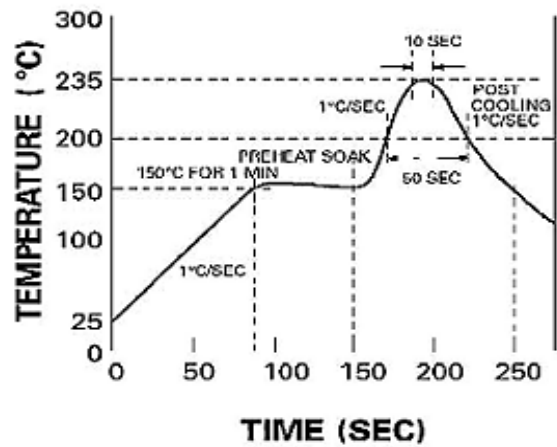
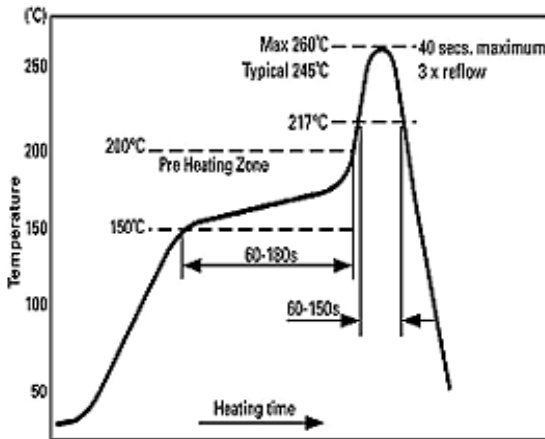

Reflow profiles in tabular form

Profile Feature	Sn-Pb System	Pb-Free System
Average Ramp-Up Rate	~3°C/second	~3°C/second
Preheat		
– Temperature Range	150-170°C	150-200°C
– Time	60-180 seconds	60-180 seconds
Time maintained above:		
– Temperature	200°C	217°C
– Time	30-50 seconds	60-150 seconds
Peak Temperature	235°C	260°C max.
Time within +0 -5°C of actual P	10 seconds	40 seconds
Ramp-Down Rate	3°C/second max.	6°C/second max.

Recommended Wave Solder Profiles

The Recommended solder Profile For Devices with Pb-free terminal plating where a Pb-free solder is used for devices with leaded terminal plating used with leaded solder

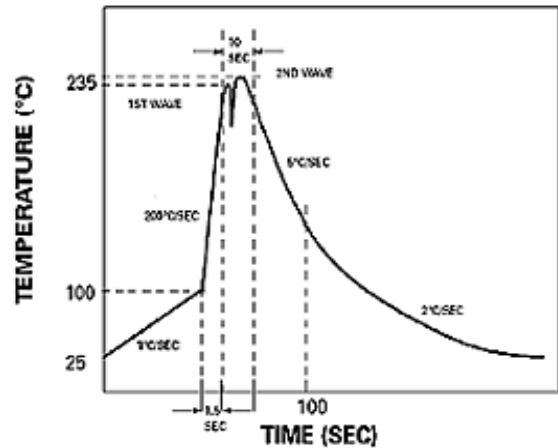
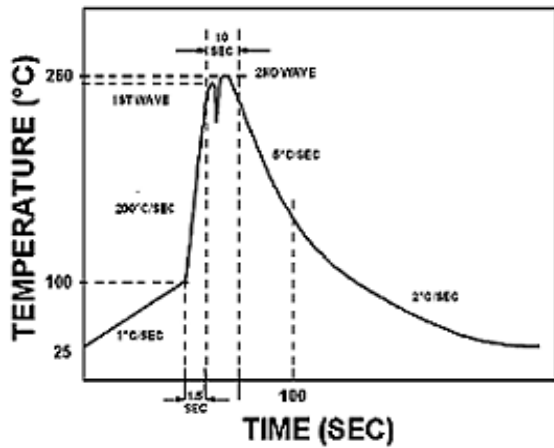

Wave Profiles in Tabular Form

Profile Feature	Sn-Pb System	Pb-free System
Average Ramp-Up Rate	~200°C/second	~200°C/second
Heating rate during preheat	Typical 1-2, Max 4°C/sec	Typical 1-2, Max 4°C/Sec
Final preheat Temperature	Within 125°C of Solder Temp	Within 125°C of Solder Temp
Peak Temperature	235°C	260°C max.
Time within +0 -5°C of actual P	10 seconds	10 seconds
Ramp-Down Rate	5°C/second max.	5°C/second max.

Typical Characteristic Curves

Fig.1: Maximum power dissipation v/s RMS on-state current

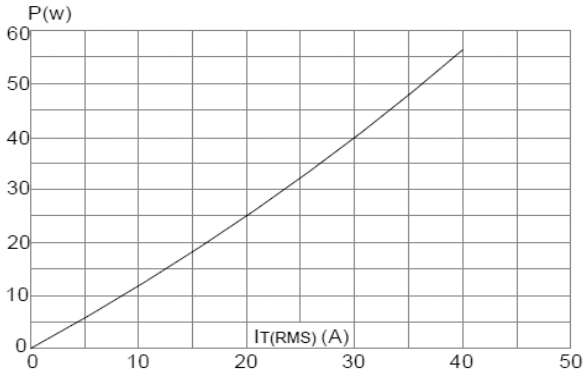

FIG.4: On-state characteristics (maximum values)

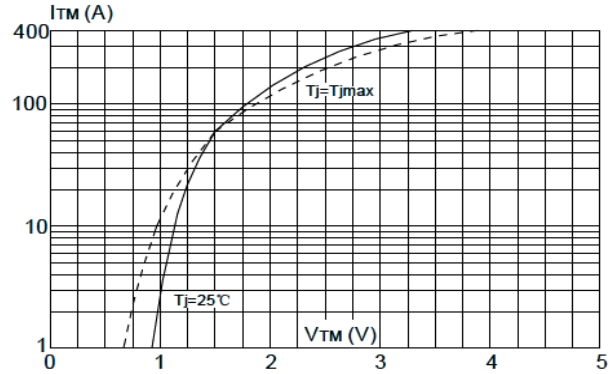

FIG.2: RMS on-state current versus case temperature

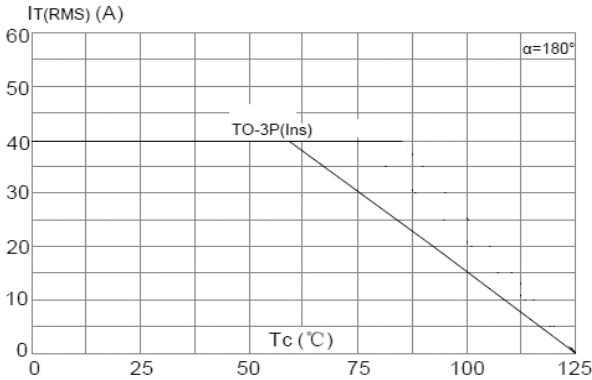

FIG.5: Non-repetitive surge peak on-state current for a sinusoidal pulse with width $t_p < 20\text{ms}$, and corresponding value of $I t$ ($di/dt < 50\text{A}/\mu\text{s}$)

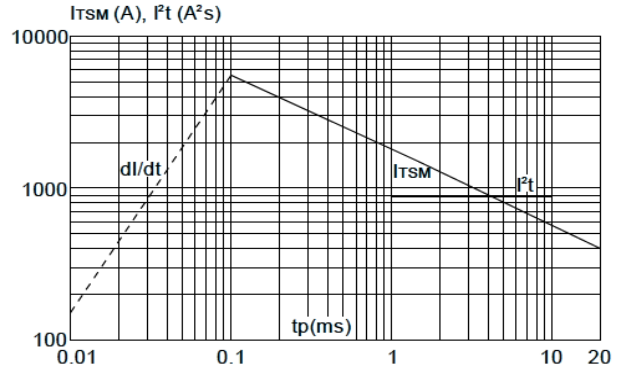

FIG.3: Surge peak on-state current versus number of cycles

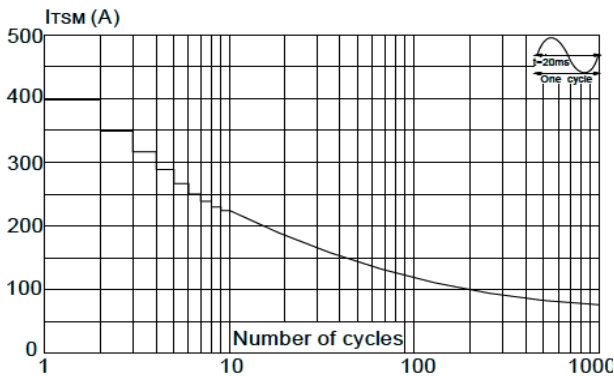
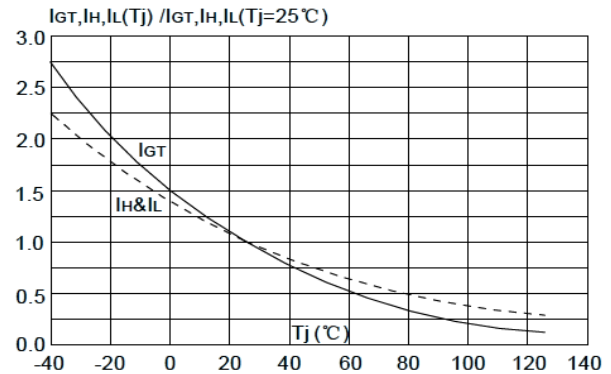

FIG.6: Relative variations of gate trigger current, holding current and latching current versus junction temperature



BTA41
Rev3_29032023EJB

Package Details

TOP-3 (Insulated Tab) Leaded Plastic Package

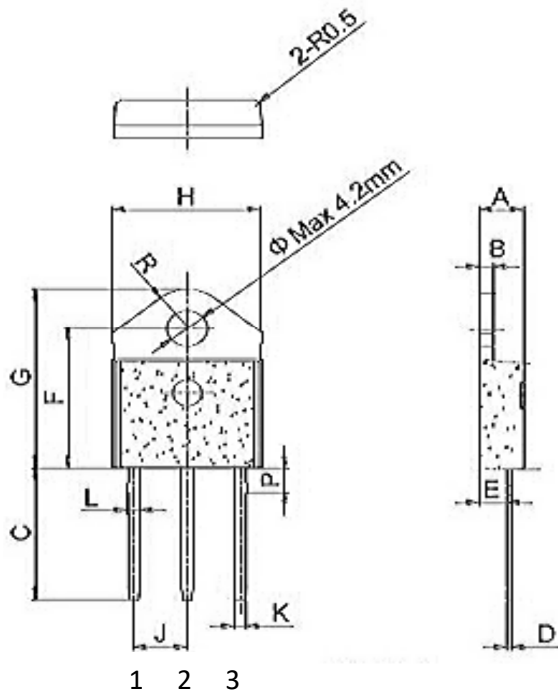

Ref.	Dimensions					
	Millimeters			Inches		
	Min.	Typ.	Max.	Min.	Typ.	Max.
A	4.40		4.60	0.173		0.181
B	1.45		1.55	0.057		0.061
C	14.35		15.60	0.565		0.614
D	0.60		0.70	0.020		0.028
E	2.70		2.90	0.106		0.114
F	15.80		16.50	0.622		0.650
G	20.40		21.10	0.803		0.831
H	16.10		16.50	0.594		0.610
J	5.40		5.65	0.213		0.222
K	1.10		1.40	0.043		0.055
L	1.35		1.50	0.053		0.059
P	2.80		3.00	0.110		0.118
R		4.35			0.171	

Pin Configuration

Pin 1: T1

Pin 2: T2

Pin 3: Gate

Ordering Information

BTA41-XXXX-XX

600: $V_{DRM}/V_{RRM} \geq 600V$
 800: $V_{DRM}/V_{RRM} \geq 800V$
 1200: $V_{DRM}/V_{RRM} \geq 1200V$

CW: $I_{GT1-3} \leq 35mA$
 BW: $I_{GT1-3} \leq 50mA$
 B: $I_{GT(1-3)} \leq 50mA, I_{GT(4)} \leq 70mA$



Continental Device India Pvt. Limited

An IATF 16949, ISO9001 and ISO 14001/ISO 45001 Certified Company



Recommended Product Storage Environment for Discrete Semiconductor Devices

This storage environment assumes that the Diodes and transistors are packed properly inside the original packing supplied by CDIL.

- Temperature 5 °C to 30 °C
- Humidity between 40 to 70 %RH
- Air should be clean.
- Avoid harmful gas or dust.
- Avoid outdoor exposure or storage in areas subject to rain or water spraying .
- Avoid storage in areas subject to corrosive gas or dust. Product shall not be stored in areas exposed to direct sunlight.
- Avoid rapid change of temperature.
- Avoid condensation.
- Mechanical stress such as vibration and impact shall be avoided.
- The product shall not be placed directly on the floor.
- The product shall be stored on a plane area. They should not be turned upside down. They should not be placed against the wall.

Shelf Life of CDIL Products

The shelf life of products is the period from product manufacture to shipment to customers. The product can be unconditionally shipped within this period. The period is defined as 2 years.

If products are stored longer than the shelf life of 2 years the products shall be subjected to quality check as per CDIL quality procedure.

The products are further warranted for another one year after the date of shipment subject to the above conditions in CDIL original packing.

Floor Life of CDIL Products and MSL Level

When the products are opened from the original packing, the floor life will start.

For this, the following JEDEC table may be referred:

JEDEC MSL Level		
Level	Time	Condition
1	Unlimited	≤30 °C / 85% RH
2	1 Year	≤30 °C / 60% RH
2a	4 Weeks	≤30 °C / 60% RH
3	168 Hours	≤30 °C / 60% RH
4	72 Hours	≤30 °C / 60% RH
5	48 Hours	≤30 °C / 60% RH
5a	24 Hours	≤30 °C / 60% RH
6	Time on Label(TOL)	≤30 °C / 60% RH

BTA41

Rev3_29032023EJ



Continental Device India Pvt. Limited

An IATF 16949, ISO9001 and ISO 14001/ISO 45001 Certified Company



Customer Notes

Component Disposal Instructions

1. CDIL Semiconductor Devices are RoHS compliant, customers are requested to please dispose as per prevailing Environmental Legislation of their Country.
2. In Europe, please dispose as per EU Directive 2002/96/EC on Waste Electrical and Electronic Equipment (WEEE).

Disclaimer

The product information and the selection guides facilitate selection of the CDIL's Semiconductor Device(s) best suited for application in your product(s) as per your requirement. It is recommended that you completely review our Data Sheet(s) so as to confirm that the Device(s) meet functionality parameters for your application. The information furnished in the Data Sheet and on the CDIL Web Site/CD are believed to be accurate and reliable. CDIL however, does not assume responsibility for inaccuracies or incomplete information. Furthermore, CDIL does not assume liability whatsoever, arising out of the application or use of any CDIL product; neither does it convey any license under its patent rights nor rights of others. These products are not designed for use in life saving/support appliances or systems. CDIL customers selling these products (either as individual Semiconductor Devices or incorporated in their end products), in any life saving/support appliances or systems or applications do so at their own risk and CDIL will not be responsible for any damages resulting from such sale(s).

CDIL strives for continuous improvement and reserves the right to change the specifications of its products without prior notice.



CDIL is a registered trademark of

Continental Device India Pvt. Limited

C-120 Naraina Industrial Area, New Delhi 110 028, India.

Telephone +91-11-2579 6150, 4141 1112 Fax +91-11-2579 5290, 4141 1119

email@cdil.com www.cdil.com

CIN No. U32109DL1964PTC004291

BTA41

Rev3_29032023EJB